



JIANGYIN JIAD E MACHINERY



30年国内领先的连卷设备专业制造商
30 years leading professional manufacturer of
bag-on-roll equipment in China

江阴嘉德机械有限公司 Jiangyin Jiade Machinery Co., Ltd

地址：江苏省江阴市周庄镇长寿云顾路668号
电话：+86 510 8636 3369
传真：+86 510 8636 3369
手机：+86 152 6163 0563
+86 150 5217 5933
邮箱：Owen@gader-cn.com

Add:No.668 Yungu Road,Changshou,Zhouzhuang
Town,Jiangyin City,Jiangsu Pro.
Tel:+86 510 8636 3369
Fax:+86 510 8636 3369
Mob:+86 152 6163 0563
+86 150 5217 5933
E-mail:Owen@gader-cn.com

更多详细资料，请登录网站
For more details, please visit the website

<http://www.jyjiade.com>

更多详情

扫描二维码



- 版面有限，本手册仅介绍了嘉德公司的部分产品。
- 其它产品未能详尽列出，敬请谅解。
- 如需详尽的了解嘉德公司的产品。
- 敬请访问嘉德公司网站或来电咨询。

© 嘉德企业(JIAD E INDUSTRY)版权所有
采用生态之印刷

●本画册的图像，文字著作权归属江阴嘉德机械有
限公司。未经本公司书面同意，不得复制或复制。
违者江阴嘉德机械有限公司保留追究其法律责任。

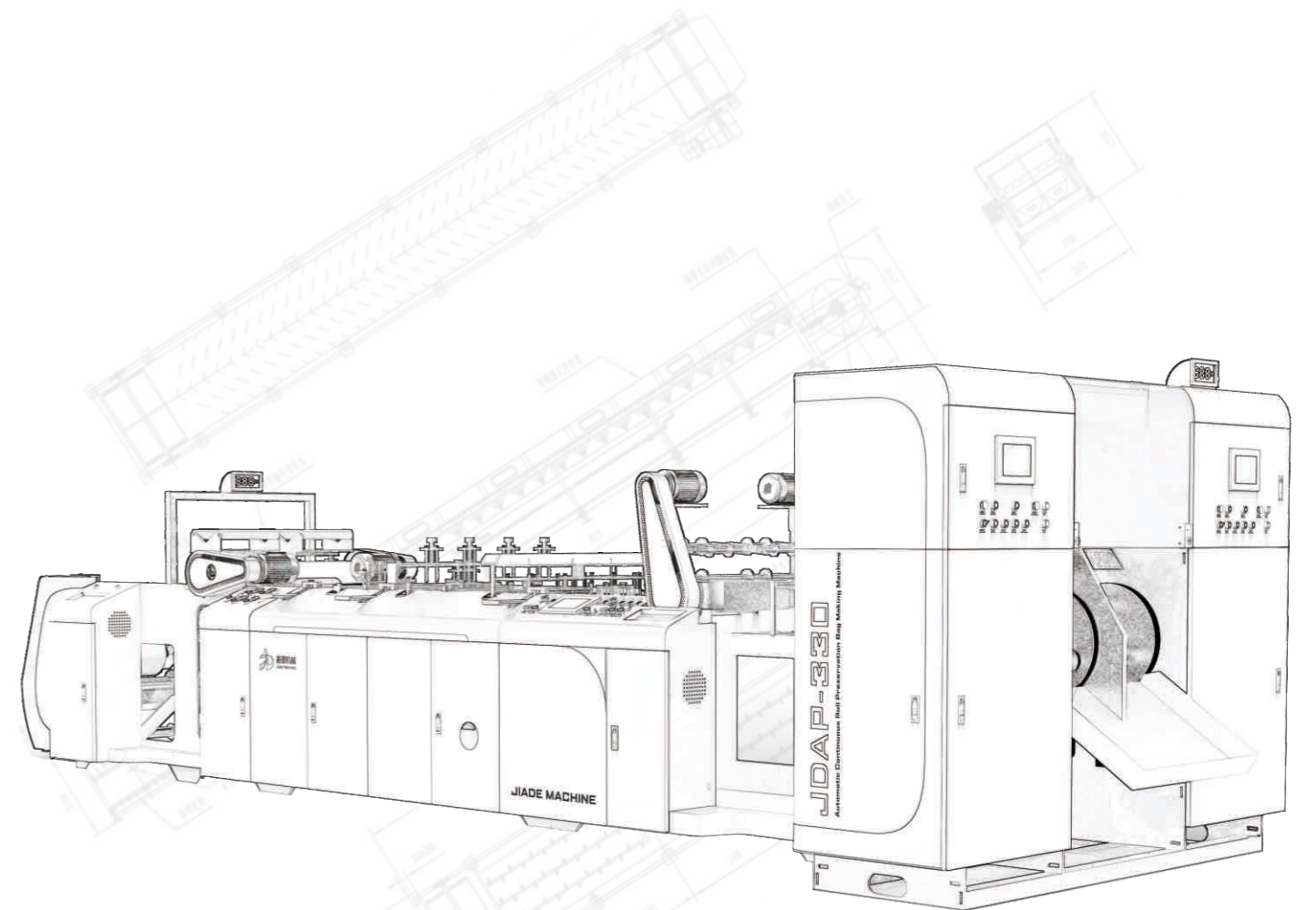

高产 高效 自动化
www.jyjiade.com

ABOUT JIADE 走进嘉德

江阴嘉德机械有限公司是一家专注于塑料软包装机械设备的研发，生产，销售的企业，具有多年的生产经验，在国内同行中处于领先地位。

公司坐落于交通便利、经济发展有前景的无锡江阴，周围有各种生产厂家。

在市场竞争激烈的今天，我们坚持“质量赢得市场，诚信铸就品质，服务造就口碑，创新智领未来”的经营理念，紧跟市场步伐，以先进的制造技术，完善的管理体系，为每一位客户提供可靠的产品与合理的方案。

嘉德公司愿与您携手同行，开拓进取，共创辉煌！竹工业集聚区，东临上海、南接无锡、西连常州、北濒泰州，地理位置优越，交通十分便利。

Jiangyin Jiade Machinery Co., Ltd. is an enterprise focusing on the R&D, production and sales of plastic soft packaging machinery and equipment. It has many years of production experience and is in the leading position in the domestic counterparts. The company is located in Jiangyin, Wuxi, with convenient transportation and promising economic development.

In today's fierce market competition, we adhere to the business philosophy of "quality wins the market, integrity forges quality, service builds public praise, innovation leads the future", keep up with the market pace, with advanced manufacturing technology, perfect management system, to provide every customer with reliable products and reasonable solutions.

We are willing to go hand in hand with you to forge ahead and create brilliance!



公司占地面积 **20,000** 平方米

The company covers an area of 20000 square meters

总资产约 **8,000** 万元

The total assets are about 80 million yuan

年生产能力达 **500** 台

The annual production capacity reaches 500 sets

员工总人数 **110** 余人

The total number of employees is more than 110

公司拥有新型专利 **20** 余项

The company has more than 20 patents

HONOR CERTIFICATE 荣誉证书

建立卓有成效的品牌建设之路，使集团发展更具规范性，广阔性。在产品制造领域，我们已取得多种行业权威认证：在企业经营领域我们获得来自社会各方的积极认可，是品质、细节、认真、坚持让品牌更具活力；是标准、责任、荣誉和使命鞭策我们承载过去，开创未来。

Establishing a fruitful brand building path to make the group's development more standardized and broad. In the field of product manufacturing, we have obtained a variety of industry authority certification: in the field of enterprise management, we have obtained positive recognition from all sectors of society, which is the quality, details, conscientiousness and persistence to make the brand more dynamic; it is the standard, responsibility, honor and mission that urge us to carry the past and create the future.



FOCUSING ON THE R&D
JIAD E MACHINERY

目录 CONTENTS

JDSZ-300×2 全自动双通道左右分开高速八折连背制袋机 Automatic Double-line Star Sealing T-shirt Bag/Flat Bag-On-Roll Making Machine	05
JDAP-400×2/500×2/600×2 双通道纸管自动换卷连卷保鲜袋制袋机 Automatic Double-line Vegetable Bag-On-Roll Making Machine (With Core)	06
JDAP-400×2/500×2/600×2 双通道纸管自动换卷连卷背心袋保鲜袋制袋机 Automatic Double-line T-shirt Vegetable Bag-On-Roll Making Machine (With core)	07
JDDT-800/1000/1200/1300 全自动穿绳袋制袋机 Automatic Draw Tape Bag-On-Roll Making Machine	08
JDDH-300×2/400×2 全自动双通道高速八折平口制袋机 Automatic Double-line High-speed Star Sealing Flat Bag-On-Roll Making Machine	09
JDSZ-300×2 全自动双通道左右分开高速八折连背制袋机 Automatic Double-line Star Sealing T-shirt Bag/Flat Bag-On-Roll Making Machine	10
JDDF-600/800/1000 自动连卷单通道四折袋制袋机 Automatic Four Fold Bag-On-Roll Making Machine	11
JDCF-600/800/1000/1200 自动连卷C-F制袋机 Automatic C-F Bag-On-Roll Making Machine	12
JDIL-400 Interleaf拉断式连卷平口袋制袋机 Semi-automatic Interleaf Star Sealing Flat Bag-On-Roll Making Machine	13
JDDA-300×2/400×2 高速双通道充气袋制袋机 High-Speed Air Bag-On-Roll Making Machine (with core)	14
JDSC-500/JDSL-500/JDDL-500 连卷背心袋制袋机 Semi-automatic T-shirt Bag-On-Roll Making Machine	15
JDDC-45-600/50-800/55-1000/65-1200 单模头吹膜机 Film Blowing Machine	16
JDDC-45×2-600/50×2-800/55×2-1000/65×2-1200 ABA吹膜机 ABA Film Blowing Machine	17
生产能力/合作伙伴 Capacity / Partner	18

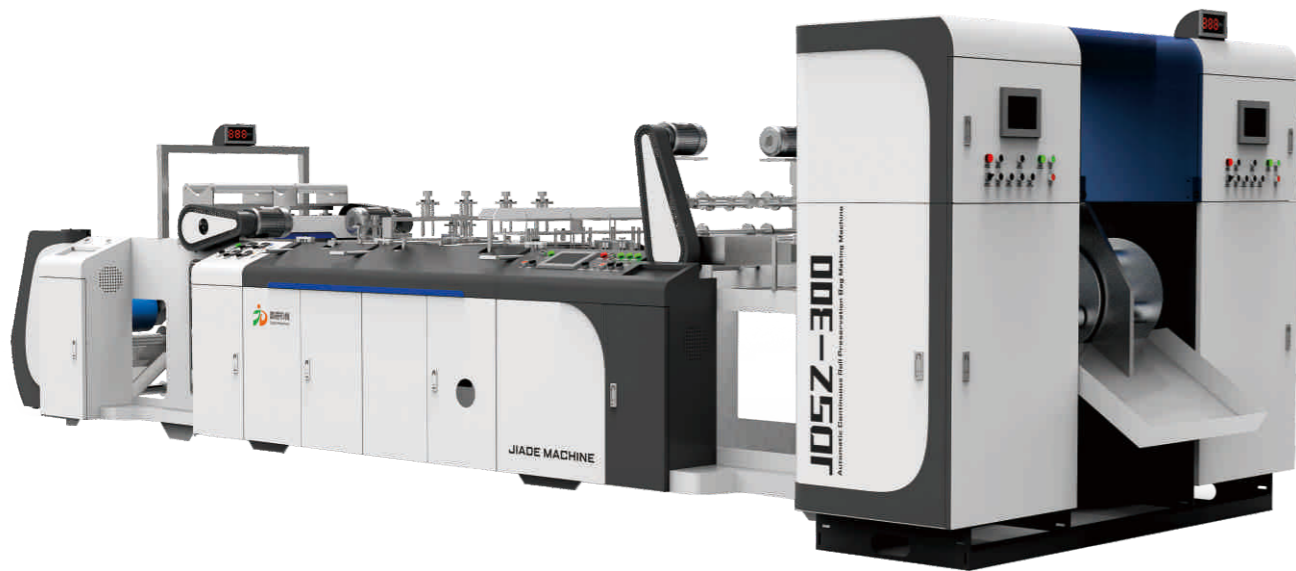

全自动双通道左右分开高速八折连背制袋机

Automatic Double-line Star Sealing T-shirt Bag/Flat Bag-On-Roll Making Machine

● 机器特性 Machine Features

此设备主要用于生产八折背心垃圾袋及八折平口垃圾袋。双通道制袋，自动换卷，收卷整齐，个数准确。

This equipment is mainly used to produce rolling star sealing T-shirt bag and rolling star sealing flat bag, double lines, automatic roll changing, neat winding, accurate counting.



技术参数 Technical Parameter

项 目	Items	JDSZ-300×2
制袋宽度	Bag making width	80-180mm
制袋长度	Bag making length	500-1500mm
制袋速度	Bag making speed	40-200只/分钟×2 for 八折平口袋 40-200pcs/min×2 for Rolling star sealing flat bag 40-160只/分钟×2 for 八折连背袋 40-160pcs/min×2 for Rolling star sealing T-shirt bag
制袋厚度	Bag making thickness	0.006-0.025mm
制袋形式	Bag making methods	连卷平口袋或连卷连背袋 Rolling star sealing flat bag or rolling star sealing T-shirt bag
温控区间	Temperature control zone	8区 8 Zones
温控精度	Temperature control precision	±1°C
加热总功率	Total heating power	5kw
总 功 率	Total power	18kw
总 重 量	Total weight	3200kg
整机尺寸	Overall dimension	6000×2200×2100mm



双通道纸管自动换卷连卷保鲜袋制袋机

Automatic Double-line Vegetable Bag-On-Roll Making Machine(With Core)

● 机器特性 Machine Features

此设备主要用于生产带纸管的保鲜袋，收卷整齐，无拉伸设计，底封效果极佳。

This machine is mainly used for producing vegetable bag with core, neat rewinding, non-stretch design, excellent bottom sealing.



技术参数 Technical Parameter

项目	Item	JDAP-400×2	JDAP-500×2	JDAP-600×2
制袋宽度	Bag making width	80-300mm	100-400mm	100-500mm
制袋长度	Bag making length	100-500mm	100-500mm	100-600mm
制袋速度	Bag making speed	60-350pcs/min×2		
制袋厚度	Bag making thickness	0.006-0.025mm		
制袋形式	Bag making method	连卷保鲜袋 Vegetable bag on roll		
温控区	Temperature control zone	4区 4 Zones		
加热总功率	Total heating power	5kw	5kw	5kw
总功率	Total power	19.5kw	19.5kw	19.5kw
总重量	Total weight	2800kg	3000kg	3200kg
整机尺寸	Overall dimension	6200×2200×1900mm	6200×2400×1900mm	6200×2600×1900mm

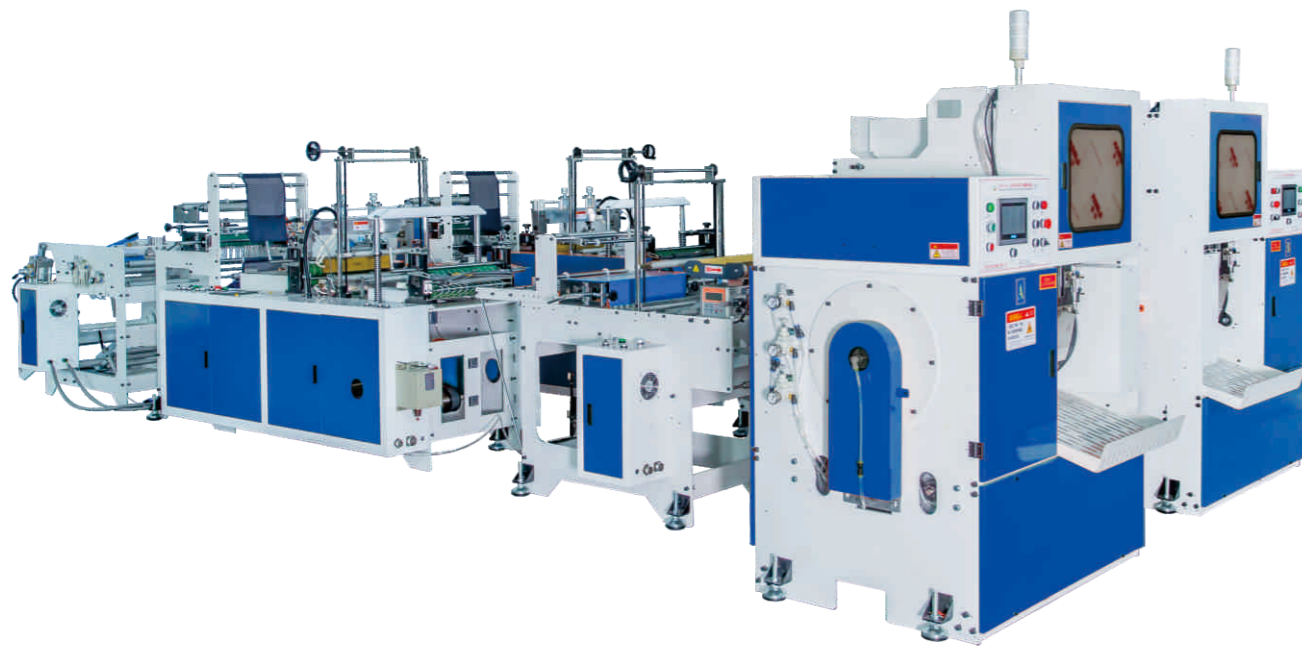

双通道纸管自动换卷连卷背心袋保鲜袋制袋机

Automatic Double-line T-shirt /flat Vegetable Bag-On-Roll Making Machine(with core)

● 机器特性 Machine Features

此设备主要用于生产带纸管的保鲜袋,既可做平口保鲜袋,也可做背心袋保鲜袋,收卷整齐,无拉伸设计,底封效果极佳。

This machine is mainly used for producing Vegetable bag with core.It can produce both flat vegetable bag and T-shirt vegetable bag.Neat rewinding,non-stretch design,excellent bottom sealing.



技术参数 Technical Parameter

项目	Item	JDAP-400×2	JDAP-500×2	JDAP-600×2
制袋宽度	Bag making width	80-300mm	100-400mm	100-500mm
制袋长度	Bag making length	100-500mm	100-500mm	100-600mm
制袋速度	Bag making speed	平口保鲜袋 Flat vegetable bag:60-230pcs/min×2		
		背心袋保鲜袋 T-shirt Vegetable bag:40-190pcs/min×2		
制袋厚度	Bag making thickness	0.006-0.025mm		
制袋形式	Bag making method	连卷平口保鲜袋 Flat Vegetable bag on roll		
		连卷背心袋保鲜袋 T-shirt vegetable bag on roll		
温控区	Temperature control zone	4区 4 Zones		
加热总功率	Total heating power	5kw	5kw	5kw
总功率	Total power	18kw	18kw	18kw
总重量	Total weight	3000kg	3200kg	3400kg
整机尺寸	Overall dimension	6200×2200×1900mm	6200×2400×1900mm	6200×2600×1900mm

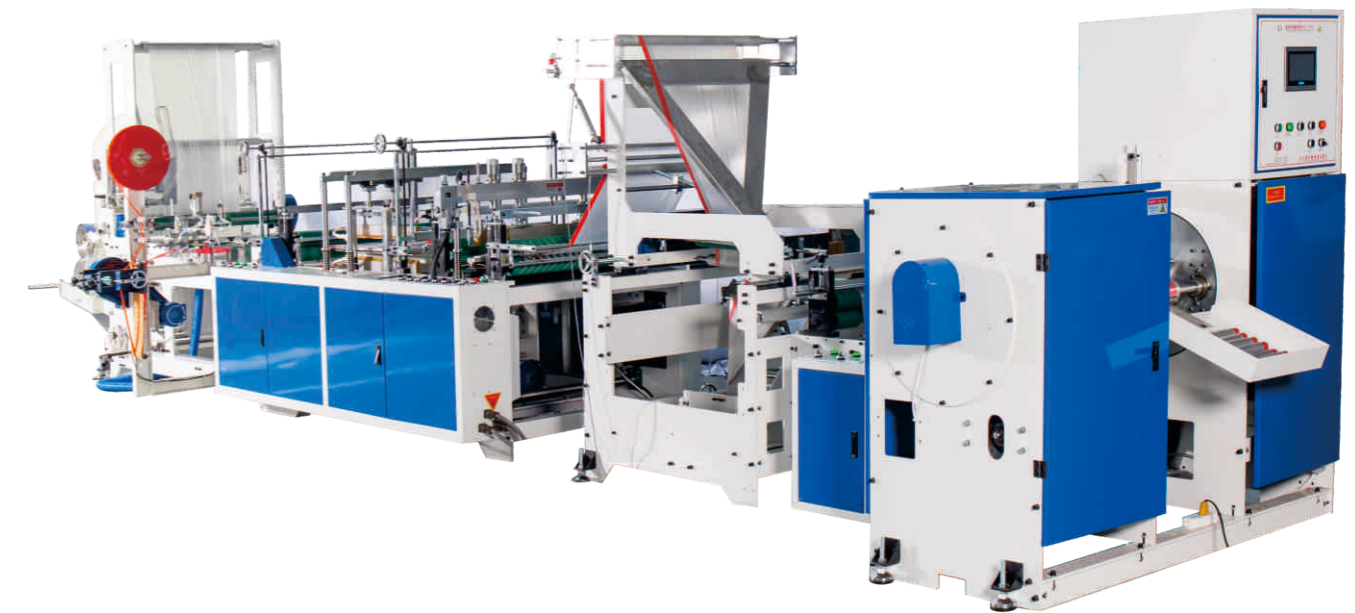

全自动穿绳袋制袋机

Automatic Draw Tape Bag-On-Roll Making Machine

● 机器特性 Machine Features

此设备为生产连卷穿绳袋专用设备,采用双伺服电机控制送料,制袋速度快,调节简单。无拉伸缝使袋子更牢固,自动换卷可以节省人工,大大提高效率。

This machine is used for producing rolling draw tape bags, adapting double servo motor control feeding, high capacity, easily operating. No stretch of sewing to make the bag more solid, automatic roll changing can save labor and improve working efficiency.



技术参数 Technical Parameter

项目 Items	JDDT-800	JDDT-1000	JDDT-1200	JDDT-1300
制袋宽度 Bag making width	400-650mm	500-850mm	500-1000mm	800-1100mm
制袋长度 Bag making length	400-680mm	400-880mm	400-1080mm	400-1180mm
制袋速度 Bag making speed	40-160只/分钟 40-160pcs/min	40-120只/分钟 40-120pcs/min	30-90只/分钟 30-90pcs/min	25-70只/分钟 25-70pcs/min
制袋厚度 Bag making thickness	HDPE:0.007-0.02mm	HDPE:0.007-0.02mm	HDPE:0.007-0.02mm	HDPE:0.007-0.02mm
	LDPE:0.02-0.05mm	LDPE:0.02-0.05mm	LDPE:0.02-0.05mm	LDPE:0.02-0.05mm
加热总功率 Total heating power	连卷穿绳袋 Rolling draw tape bag	连卷穿绳袋 Rolling draw tape bag	连卷穿绳袋 Rolling draw tape bag	连卷穿绳袋 Rolling draw tape bag
自动换卷频率 Automatically roll change frequency	11卷/分钟 11 rolls/min	11卷/分钟 11 rolls/min	11卷/分钟 11 rolls/min	11卷/分钟 11 rolls/min
总功率 Total power	15kw	15kw	24kw	27kw
总重量 Total weight	3200kg	3400kg	3800kg	4300kg
整机尺寸 Overall dimension	7000×2000×2200mm	7000×2000×2200mm	7000×2000×2600mm	7000×2400×2900mm

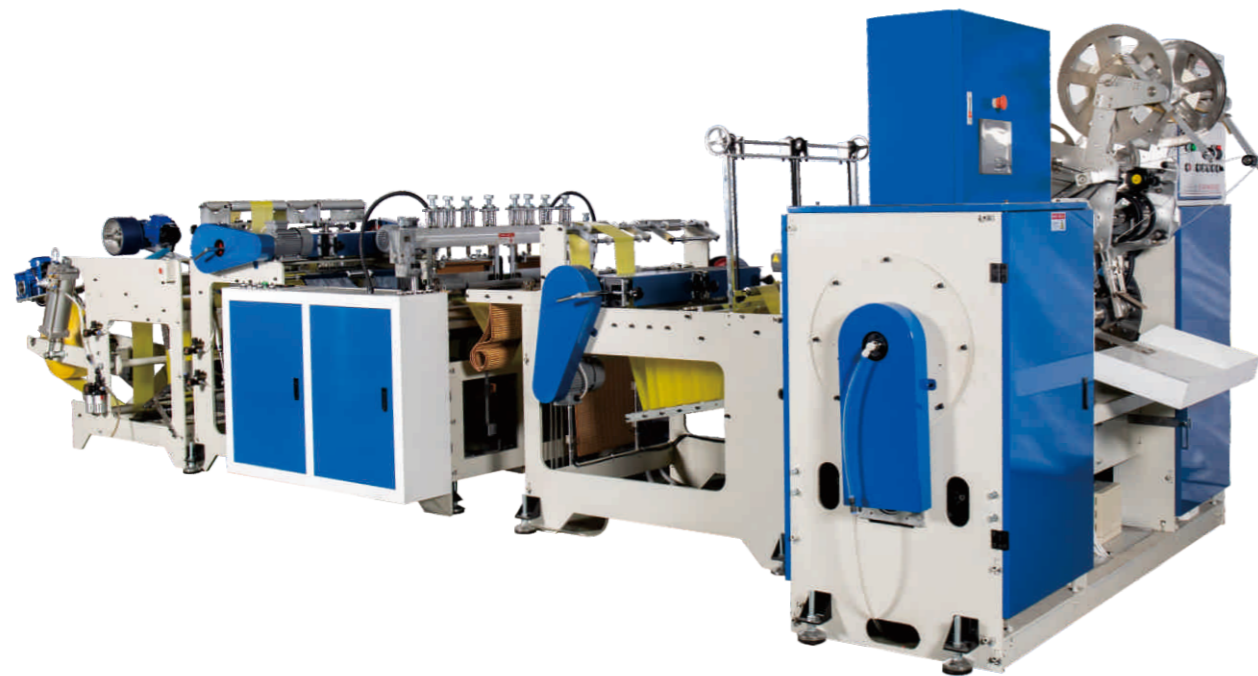

全自动双通道高速八折平口制袋机

Automatic Double-line High-speed Star Sealing Flat Bag-On-Roll Making Machine

● 机器特性 Machine Features

此设备为生产八折平口垃圾袋的专用设备，双通道高速无拉伸制袋，底封好，独立自动换卷，收卷整齐，个数准确。主动放料，薄膜张力稳定，可自动贴标。

This equipment is specialized in producing rolling star sealing flat bag, double lines, high-speed non-stretch bag making, bottom sealing, independent automatic roll changing, neat winding, accurate counting. Active discharge, film tension and stability, automatic labeling.



技术参数 Technical Parameter

项 目	Items	JDDH-300×2	JDDH-400×2
制袋宽度	Bag making width	80-180mm	150-280mm
制袋长度	Bag making length	100-1200mm	100-1500mm
制袋速度	Bag making speed	60-220只/分钟×2 60-220 pcs/min×2	60-220只/分钟×2 60-220 pcs/min×2
制袋厚度	Bag making thickness	0.005-0.025mm	0.006-0.025mm
制袋形式	Bag making methods	连卷八折平口袋或连卷平口袋	连卷八折平口袋或连卷平口袋
		Rolling star sealing flat bag or rolling flat bag	Rolling star sealing flat bag or rolling flat bag
换卷次数	Maximum Capacity	11卷/分钟 11 rolls/min	11卷/分钟 11 rolls/min
温控区间	Temperature control zone	4区 4 Zones	4区 4 Zones
总 功 率	Total power	12kw	14kw
总 重 量	Total weight	2500kg	3800kg
整机尺寸	Overall dimension	6200×2200×1800mm	6200×2800×1800mm

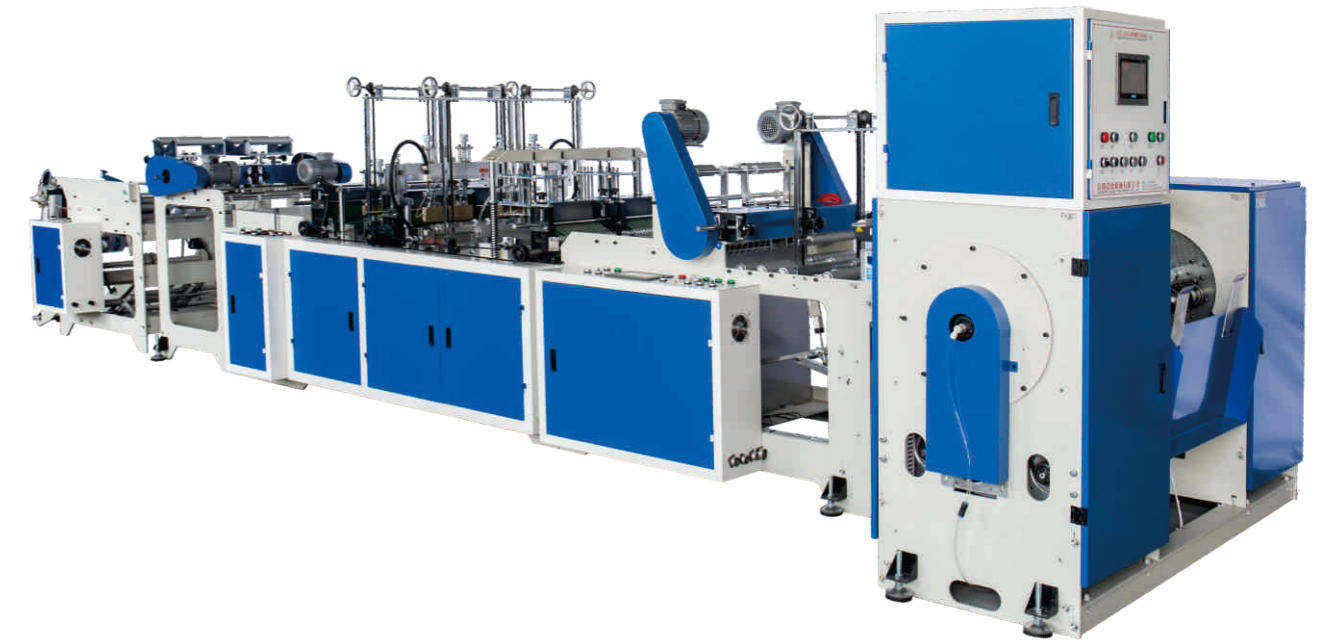

全自动双通道左右分开高速八折连背制袋机

Automatic Double-line Star Sealing T-shirt Bag/Flat Bag-On-Roll Making Machine

● 机器特性 Machine Features

此设备主要用于生产八折背心垃圾袋及八折平口垃圾袋。双通道制袋，自动换卷，收卷整齐，个数准确。

This equipment is mainly used to produce rolling star sealing T-shirt bag and rolling star sealing flat bag, double lines, automatic roll changing, neat winding, accurate counting.



技术参数 Technical Parameter

项 目	Items	JDSZ-300×2
制袋宽度	Bag making width	80-180mm
制袋长度	Bag making length	500-1500mm
制袋速度	Bag making speed	40-160只/分钟×2 for 八折平口袋 40-160pcs/min×2 for rolling star sealing flat bag
		40-140只/分钟×2 for 八折连背袋 40-140pcs/min×2 for rolling star sealing T-shirt bag
制袋厚度	Bag making thickness	0.006-0.025mm
制袋形式	Bag making methods	连卷平口袋或连卷连背袋
		Rolling star sealing flat bag or rolling star sealing T-shirt bag
温控区间	Temperature control zone	8区 8 Zones
温控精度	Temperature control precision	±1°C
加热总功率	Total heating power	5kw
总 功 率	Total power	18kw
总 重 量	Total weight	3200kg
整机尺寸	Overall dimension	6000×2200×2100mm

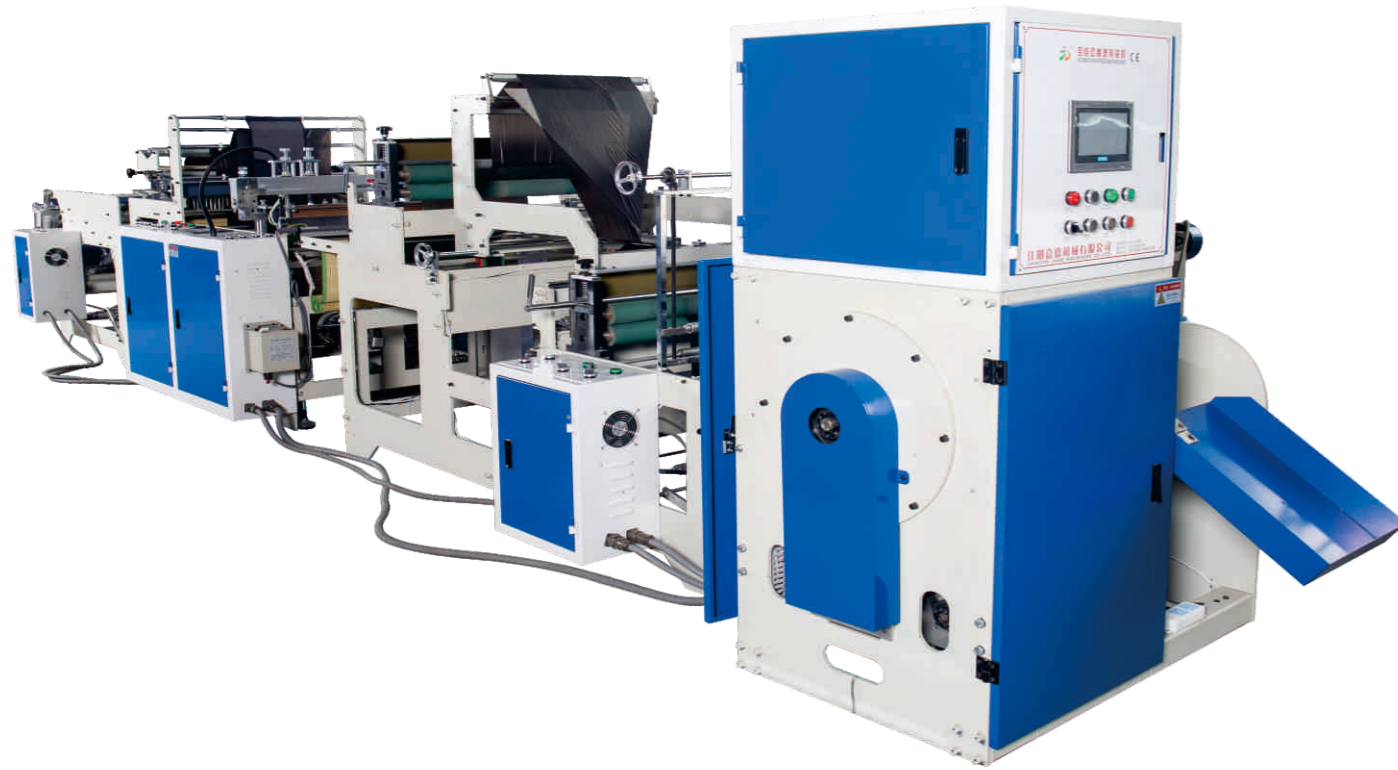

自动连卷单通道四折袋制袋机

Automatic Four Fold Bag-On-Roll Making Machine

● 机器特性 Machine Features

此设备为生产连卷四折平底垃圾袋的专用设备,单通道制袋,自动换卷,收卷整齐。

This machine is specialized in producing rolling four fold flat bag, single line, roll change automatically, neat winding.



技术参数 Technical Parameter

项 目	Items	JDDF-600	JDDF-800	JDDF-1000
制袋宽度	Bag making width	80-500mm	80-700mm	80-900mm
制袋长度	Bag making length	100-1500mm	100-1500mm	100-1500mm
制袋速度	Bag making speed	40-180只/分钟 40-180pcs/min	40-150只/分钟 40-150pcs/min	40-120只/分钟 40-120pcs/min
制袋厚度	Bag making thickness	0.006-0.025mm		
制袋形式	Bag making methods	连卷平底四折袋 Rolling four fold flat bag		
加温总功率	Total heating power	1.6kw		
温控区间	Temperature control zone	2区 2 Zones		
总 功 率	Total power	9kw	11kw	13kw
总 重 量	Total weight	1800kg	1800kg	2200kg
整机尺寸	Overall dimension	4500×1100×2100mm	4500×1100×2100mm	5500×1500×2100mm



自动连卷C-F制袋机

Automatic C-F Bag-On-Roll Making Machine

● 机器特性 Machine Features

此设备为生产连卷C-F平底垃圾袋的专用设备,单通道制袋,自动换卷,收卷整齐。

This machine is specialized in producing rolling flat C-F bag, single line, automatically roll changing, neat rewinding.



技术参数 Technical Parameter

项 目	Items	JDCF-600	JDCF-800	JDCF-1000	JDCF-1200
制袋宽度	Bag making width	80-500mm	80-700mm	80-900mm	80-1100mm
制袋长度	Bag making length	100-1200mm	100-1200mm	100-1500mm	100-1500mm
制袋速度	Bag making speed	40-180只/分钟 40-180pcs/min	40-160只/分钟 40-160pcs/min	40-150只/分钟 40-150pcs/min	40-120只/分钟 40-120pcs/min
制袋厚度	Bag making thickness	0.008-0.05mm			
制袋形式	Bag making methods	连卷C-F袋 C-F bag-on-roll			
温控区间	Temperature control zone	2区 2 Zones			
加温总功率	Total heating power	1.2kw	1.5kw	1.8kw	2.0kw
总 功 率	Total power	10kw	11kw	13kw	15kw
总 重 量	Total weight	About 2000kg	About 2500kg	About 3000kg	About 3500kg
整机尺寸	Overall dimension	6200×1400×2200mm	6200×1600×2200mm	6200×1800×2200mm	6200×2000×2200mm

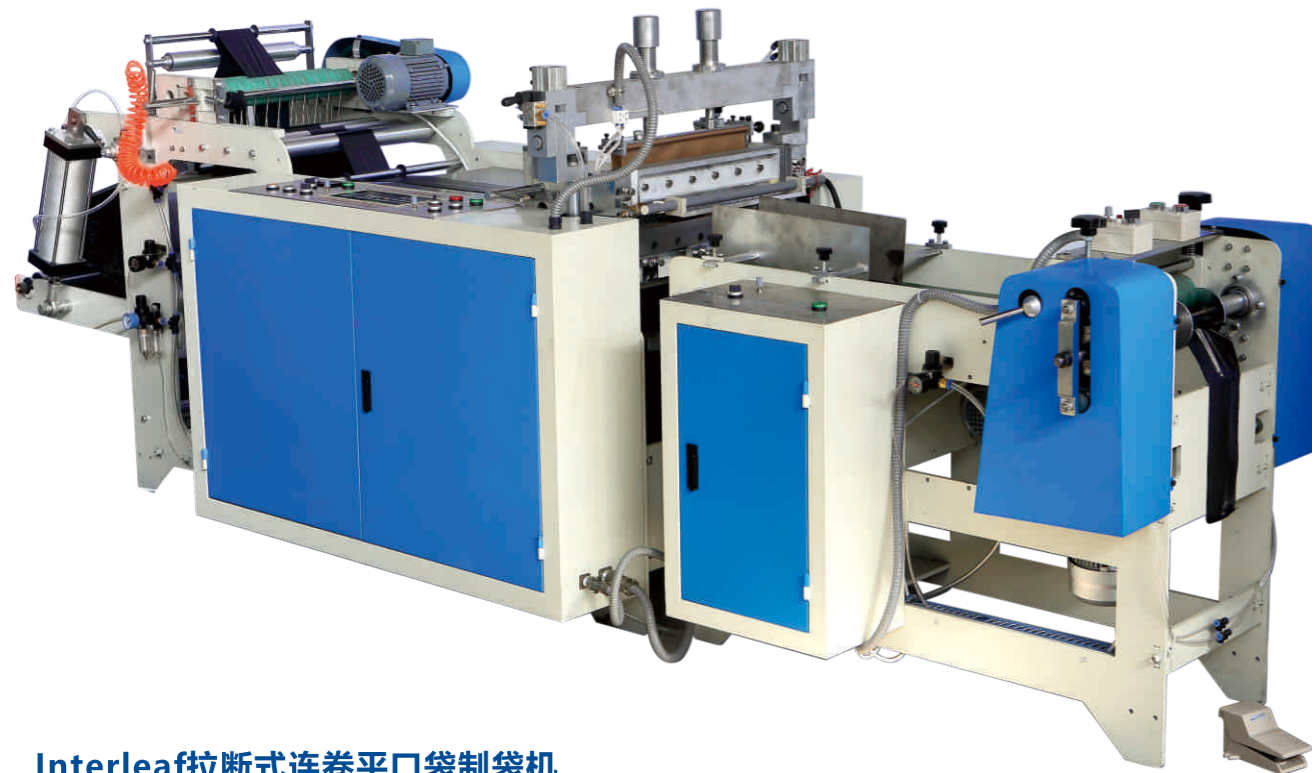

Interleaf拉断式连卷平口袋制袋机

Semi-automatic Interleaf Star Sealing Flat Bag-On-Roll Making Machine

● 机器特性 Machine Features

此机生产拉断式连卷八折平口袋，八折平口单个连卷，可做抽取式包装。

This equipment is used for producing rolling interleaf star sealing flat bag, this kind of bag can be packed as extractive packaging.



技术参数 Technical Parameter

项 目	Items	JDIL-400
制袋宽度	Bag making width	80-200mm
制袋长度	Bag making length	400-1500mm
制袋速度	Bag making speed	30-90只/分钟 30-90pcs/min
制袋厚度	Bag making thickness	0.006-0.025mm
制袋形式	Bag making methods	拉断连卷八折平口袋 Interleaf Star Sealing Flat Bag
温控区间	Temperature control zone	2区 2 Zones
加温总功率	Total heating power	1.4kw
总 功 率	Total power	8kw
总 重 量	Total weight	1800kg
整机尺寸	Overall dimension	4500×900×1400mm

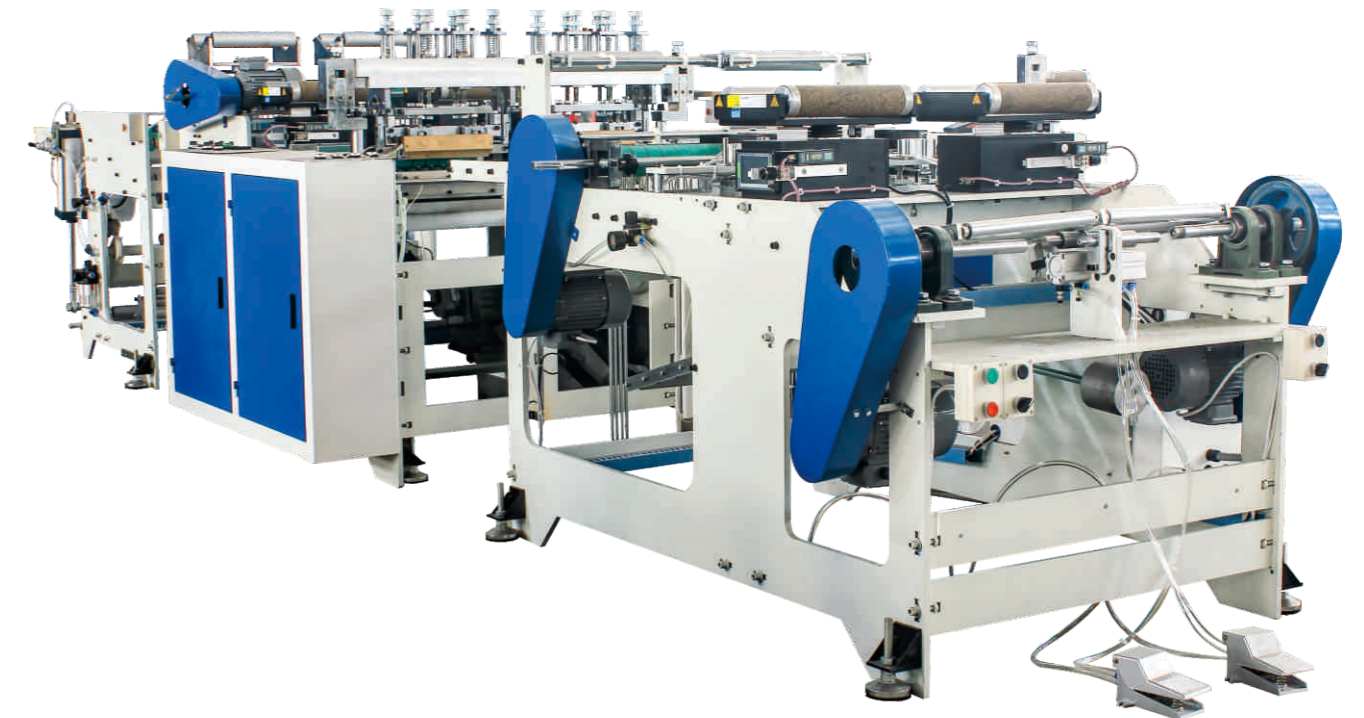

高速双通道充气袋制袋机

High-Speed Air Bag-On-Roll Making Machine(with core)

● 机器特性 Machine Features

此机为生产连卷充气袋的专用设备，双通道印刷制袋，边封无拉伸，收卷自动纠偏，收卷紧，整齐。

This equipment is specialized in producing rolling air bag, double lines for printing, sealing without stretching, winding automatically correction, tight and neat winding.



技术参数 Technical Parameter

项 目	Items	JDDA-300×2	JDDA-400×2
制袋宽度	Bag making width	80-200mm	150-300mm
制袋长度	Bag making length	100-1500mm	200-1500mm
制袋速度	Bag making speed	40-210只/分钟×2 40-210pcs/min×2	40-210只/分钟×2 40-210pcs/min×2
制袋厚度	Bag making thickness	0.005-0.025mm	0.005-0.025mm
制袋形式	Bag making methods	连卷有芯充气袋 Rolling air bag with core	连卷有芯充气袋 Rolling air bag with core
加温总功率	Total heating power	2.4kw	2.8kw
温控区间	Temperature control zone	6区 6 Zones	6区 6 Zones
自动纠偏	Automatic correction	2套 2sets	2套 2sets
总 功 率	Total power	16kw	18kw
总 重 量	Total weight	2800kg	3000kg
整机尺寸	Overall dimension	5800×1300×1500mm	5800×1500×1500mm

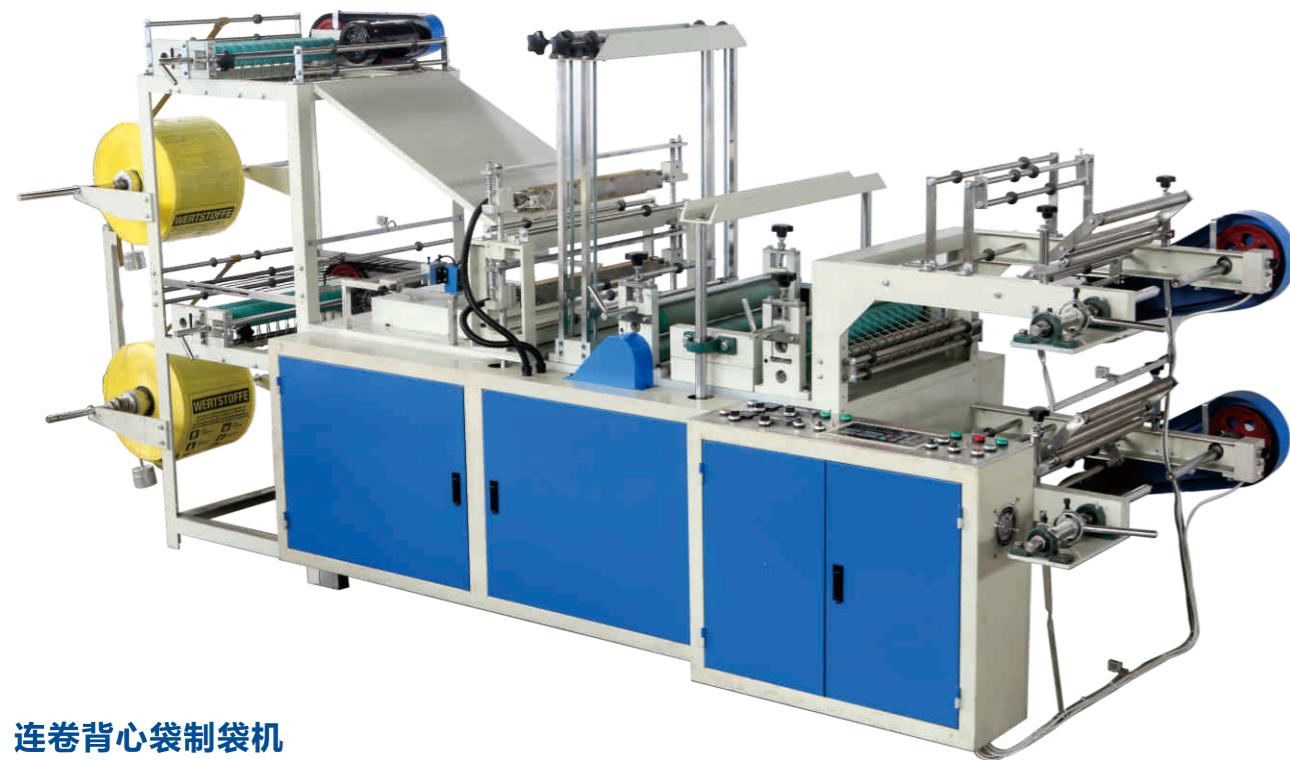

连卷背心袋制袋机

Semi-automatic T-shirt Bag-On-Roll Making Machine

● 机器特性 Machine Features

此设备生产印刷连卷平口保鲜袋及连卷背心袋，双通道双伺服制袋，收卷整齐。

This equipment is used for producing rolling flat vegetable bag and rolling T-shirt bag, double lines, double servo, neat winding.



技术参数 Technical Parameter

项 目 Items	JDSC-500型双通道双彩印 Double-lines Double-printing	JDSL-500型单通道 (单伺服) Single-line(Single Servo)	JDDL-500型双通道 (单伺服) Double-lines(Single Servo)
制袋宽度 Bag making width	100-450mm	100-450mm	100-450mm
制袋长度 Bag making length	100-1200mm	100-1200mm	500-1200mm
制袋速度 Bag making speed	40-160只/分钟 × 2 for 八折平口袋 40-130pcs/min × 2 for rolling star sealing flat bag	40-130只/分钟 for 连卷保鲜袋 40-130pcs for rolling fresh-keeping bag	40-130只/分钟 × 2 for 连卷保鲜袋 40-130pcs/min × 2 for rolling fresh-keeping bag
	40-130只/分钟 × 2 for 八折连卷袋 40-130pcs/min × 2 for rolling star sealing T-shirt bag	40-120只/分钟 for 连卷背心袋 40-120pcs for rolling T-shirt bag	40-120只/分钟 × 2 for 连卷背心袋 40-120pcs/min × 2 for rolling T-shirt bag
制袋厚度 Bag making thickness	0.006-0.025mm	0.006-0.025mm	0.006-0.025mm
制袋形式 Bag making methods	连卷保鲜袋或连卷背心袋 Rolling fresh-keeping bag or rolling T-shirt bag	连卷保鲜袋或连卷背心袋 Rolling fresh-keeping bag or rolling T-shirt bag	连卷保鲜袋或连卷背心袋 Rolling fresh-keeping bag or rolling T-shirt bag
温控区间 Temperature control zone	2区 2 Zones	1区 1 Zones	2区 2 Zones
加热总功率 Total heating power	2.8kw	1.4kw	2.8kw
总功率 Total power	11.5kw	7kw	8.5kw
总重量 Total weight	1200kg	1000kg	1100kg
整机尺寸 Overall dimension	3800 × 1000 × 1700mm	3800 × 1000 × 1700mm	3800 × 1000 × 1700mm

单模头吹膜机

Film Blowing Machine

● 机器特性 Machine Features

吹制各种规格的低密度聚乙烯、高密度聚乙烯和线性低密度聚乙烯塑料薄膜，广泛应用于食品百货、日用、化工、针纺织品、购物礼袋和工业包装。机筒、螺杆采用38CrMoAl合金材料经氮化处理精密加工而成，具有最佳的耐磨和腐蚀性。

This equipemt can blow a variety of low-density polyethylene, high-density polyethylene and linear low-density polyethylene plastic film, they are widely used in food department stores, household, chemical, textile, shopping bags and industrial packaging. Cylinder and screw adapt 38CrMoAl alloy material by nitriding precision machining, they have the best wear and corrosion resistance.



技术参数 Technical Parameter

项目 Items	JDDC-45-600	JDDC-50-800	JDDC-55-1000	JDDC-65-1200
螺杆直径 Screw diameter	Φ45mm	Φ50mm	Φ55mm	Φ65mm
螺杆长径比 Screw length proportion	28:1	28:1	28:1	28:1
产量 Production	10-40kg/h	25-50kg/h	25-65kg/h	30-80kg/h
薄膜厚度 Film thickness	HDPE:0.005-0.025mm	HDPE:0.005-0.025mm	HDPE:0.005-0.025mm	HDPE:0.005-0.025mm
	LDPE:0.02-0.09mm	LDPE:0.02-0.09mm	LDPE:0.02-0.09mm	LDPE:0.02-0.09mm
最高线速度 Max line speed of film	90米/分 90m/min	90米/分 90m/min	90米/分 90m/min	90米/分 90m/min
牵引辊宽度 Traction roll width	650mm	850mm	1050mm	1250mm
加热总功率 Heating total power	约25kw About 25kw	约30kw About 30kw	约35kw About 35kw	约40kw About 40kw
装机总功率 Installed power	35kw	40kw	50kw	65kw
整机重量 Total weight	2000kg	2500kg	3400kg	5000kg
整机尺寸 Overall dimension	5000 × 2000 × 4300mm	5000 × 2200 × 4800mm	5000 × 2200 × 5500mm	5200 × 3000 × 6500mm

ABA吹膜机

ABA Film Blowing Machine

● 机器特性 Machine Features

高产, 省电, 稳定, 低噪, 省人工, 废料少, 出膜光亮, 平整, 手感好

High-capacity, power-saving, stable, low-noise, labor-saving, less waste, bright film, smooth, good hand feeling.



技术参数 Technical Parameter

项 目	Item	JDDC-45×2-600	JDDC-50×2-800	JDDC-55×2-1000	JDDC-65×2-1200
原 料	Raw material	HDPE,LDPE,LLDPE,再生料,生物降解料等 HDPE,LDPE,LLDPE,recycling material,Compostable material			
薄膜厚度	Film thickness	HDPE:0.005-0.025mm LDPE:0.02-0.09mm			
有效宽幅	Film effective width				
吹膜有效宽幅	Film effective width	100-550mm	200-750mm	400-950mm	600-1150mm
螺杆直径	Screw diameter	Φ45mm×2	Φ50mm×2	Φ55mm×2	Φ65mm×2
螺杆长径比	L/D	28:1	28:1	28:1	28:1
最大挤出量	Max Output	20-60kg/h	30-80kg/h	30-100kg/h	40-120kg/h
装机总功率	Installation power	40kw	50kw	70kw	80kw
整机重量	Total weight	2500kg	3000kg	4000kg	5000kg
整机尺寸	Overall dimension	5200×2200×4800mm	5200×2400×5200mm	5200×2600×5800mm	5500×3000×6800mm



可私人定制任何形式的连卷设备, 团队30年研发经验, 欢迎您的光临。
Our team has more than 30 years of research and development experience, we can manufacture any custom form of rolling bag making machine.